

# DIGITAL TORQUE TESTERS

## UDT-200 & UDT-500

UDT-200 & UDT-500 series help you check the performance of oil-pulse tool and hand torque wrench at regular intervals, allowing you to store and download the data.

### FEATURES

- The built-in NiMH battery operation gives you hand-carry mobile use in your assembly site especially for pulse-tools' commencement of one day operation. AC power source from your plug can be used together.
- 11-hour continuous operation by battery is possible. Full recharging time is approx. 4-hours.
- Memory function can store maximum 250 torque data.
- Torque check and adjustment for angle nutrunner and shut-off pulse tool using optional soft-joint attachment for traceability.
- Red color LED display gives clear visual confirmation.
- PC output terminal RS-232C is built in the UDT series.
- Torque transducer mounted in pick-up has optimum function to measure oil-pulse tool.



### SPECIFICATIONS

Model	Applicable Tool Type	Torque Capacity Range (Recommended Torque Capacity Range)	Blow Capacity Range	Accuracy	Dimensions mm(about) (W × D × H)	Weight Kg(about)	Code (A) (E)	Accessories
UDT-200A (115V) -200E (230V)	Pulse Wrench, Angle Nutrunner (Soft-joint attachment assembly is required to measure shut-off type pulse wrench and angle nutrunner.) Hand torque wrench *Never use impact wrench	3 - 200 Nm (15 - 200 Nm)	0-99 blows (* )	±0.5% at rated output	Amplifier (198 × 171 × 115) Pick-up (245 × 125 × 75)	Amplifier (1.7) Pick-up (8.5)	83102 83112	Socket Adaptor (3/8) 836-520-0
								Socket Adaptor (1/2) 836-520-1
								TX-C46E-75 (Socket Bit) 919-700-0
								AC Adaptor (120V) 910-217-0
UDT-500A (115V) -500E (230V)	Pulse Wrench, Angle Nutrunner (Soft-joint attachment assembly is required to measure shut-off type pulse wrench and angle nutrunner.) Hand torque wrench *Never use impact wrench	30 - 500 Nm (150 - 500 Nm)	0-99 blows (* )	±0.5% at rated output	Amplifier (198 × 171 × 115) Pick-up (280 × 150 × 90)	Amplifier (1.7) Pick-up (15.0)	83132 83142	AC Adaptor (230V) 910-218-0
								Socket Adaptor (1/2) 836-520-7
								Socket Adaptor (5/8) 836-520-8
								Socket Adaptor (3/4) 836-520-9
								AC Adaptor (120V) 910-217-0
								AC Adaptor (230V) 910-218-0

(\*) On condition that blow measurements start when input torque exceeds 60% of peak torque. Operating Voltage: 120V for UDT-\*\*A, 220V for UDT-\*\*E Operating Environment: (10-40°C) Humidity (20-80%), No Dew.

### OPTION

#### Soft-joint Attachment Assembly

##### UDT-200

For pulse tools or angle nutrunner



(M8) 878-740-1



(M10) 836-890-7



(M12) 836-890-9



(M14) 878-840-1



(M16) 878-800-1



(M18) 878-804-1

For angle nutrunner



(M8) 836-890-1



(M10) 836-890-2



(M12) 836-890-5



(M20) 878-807-1

Choose the correct size for your usage.

Other optional soft-joint attachment assemblies are available. Please contact your nearest URYU distributor.

## UDT-25

UDT-25 is designed to check fastening torque and its number of pulses for the small models (e.g. UL30, 40 and UAT30D · 40 · 50) with the torque capacity range 0.3 Nm-25 Nm.

### FEATURES

- Compact design for torque measurement and torque display sections gives hand-carry mobile.
- Power source is nickel hydride battery. Full recharging time is approx. 4-hours. 11-hour continuous operation is possible after full charging. \*1
- Applicable to reversing torque as well. \*2
- UDT-25 tester can be used to check the capacity of US-LT, US-LD, and hand torque wrench as well.
- Red color LED display gives you clear visual confirmation.
- Supreme accuracy of within  $\pm 0.5\%$  at the rated output.
- The RS232C port for data output is built in the UDT-25 tester.
- Data storage capacity: 250 data points.



\*1: Never use during charging.

\*2: Only forward rotation is available for Soft-Joint Attachment.

### SPECIFICATIONS

Model	Applicable Tool Type	Torque Capacity Range (Recommended Torque Capacity Range)	Blow Capacity Range	Accuracy	Power Source	Environmental Condition	Dimensions mm (about)	Weight kg (about)	Code	Accessories
UDT-25A (115V)	Pulse Wrench, Torque Control Screwdriver, Direct Drive Screwdriver, Angle Nutrunner, Hand Torque Wrench	0.3 - 25 Nm (2 - 25 Nm)	0 - 99 blows (*)	$\pm 0.5\%$ at rated output	Built-in Nickel Hydride Battery	Operation Temperature: 10 - 40°C (No Dew) Humidity: 20 - 80% (No Dew)	190 (W) × 180 (D) × 59 (H)	2.3	83062	Carrying Case 910-955-0
										AC Adapter (115V) 910-950-0
										AC Adapter (230V) 910-951-0
										Test Socket (3/8") 830-520-6
UDT-25E (230V)	Hexagon Socket Bit (13 × 100) 918-223-0	Driver Adaptor 919-700-0								
		Soft Joint Attachment 830-890-6								
		Soft Joint Attachment 830-890-7								
									Hexagon Head Bolt (M8 × 20) 946-928-0	

(\*) On condition that blow measurements start when input torque exceeds 60% of peak torque. Operating Environment : (10-40°C, no freeze) Humidity(20-80%), No Dew

### Soft joint Attachments



830-890-6 / For Pulse Tools



830-890-7 / For Screwdrivers

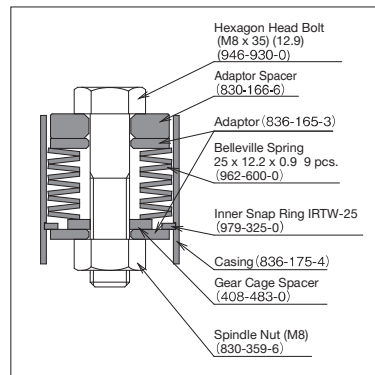
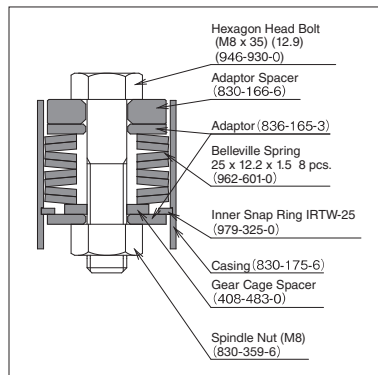

# DIGITAL TORQUE TESTERS

## UET SERIES

URYU UET-10CUA/10CUE torque tester is designed to check output torque of US-LT series Torque-Control Screwdriver. Its built-in torque sensor shows the torque reading on LED display.

### FEATURES

- Its built-in torque sensor reads the torque ranging from 0.1 to 10 Nm.
- LED digital display helps you read the reading in the darkness.
- Hit the RESET button for zero point adjustment.
- Supreme accuracy: within  $\pm 0.5\%$ .
- The CAL diagnostic features help you find any error in the built-in amplifier.
- The portability with a built-in battery helps you check tools on site.
- The soft-joint attachment comes standard with UET-10CU tester, which allows you to simulate the actual application.
- The USB/RS232C port for data output is built in the UET-10CU tester.
- Full recharging time is approx. 2-hours. 16-hour continuous operation is possible after full charging.



Never use during charging.

### SPECIFICATIONS

Model	Applicable Tool Type	Torque Capacity Range (Recommended Torque Capacity Range)	Accuracy	Power Source	Environmental Condition	Dimensions (unit: mm)	Weight (about)	Code	Accessories
UET-10CUA (115V)	US-LT series Torque-Control Screwdriver Small-type Hand Torque Wrench	0.1 - 10 Nm (0.15 - 10 Nm)	$\pm 0.5\%$ at rated output	Built-in Nickel Hydride Battery	Operation Temperature: 0 - 40°C (No Dew) Humidity: 30 - 90% (No Dew)	160 (W) × 190 (D) × 65 (H)	2.3 kg	83932	Carrying Case 909-418-0
UET-10CUE (230V)									AC Adapter (115V) 910-907-0
								83942	AC Adapter (230V) 910-908-0
									Hexagon Socket Bit (13 × 100) (5 Hex) 918-129-0
									Hexagon Socket Bit (13 × 100) (6.35 Hex) 918-223-0
									Driver Attachment Assembly 836-890-4
									Hexagon Head Bolt (M8 × 20) (12.9) (For Hard Joint) 946-928-0
									Plate Spring 25 × 12.2 × 1.5 962-601-0

### Driver Attachment Assembly



836-890-4

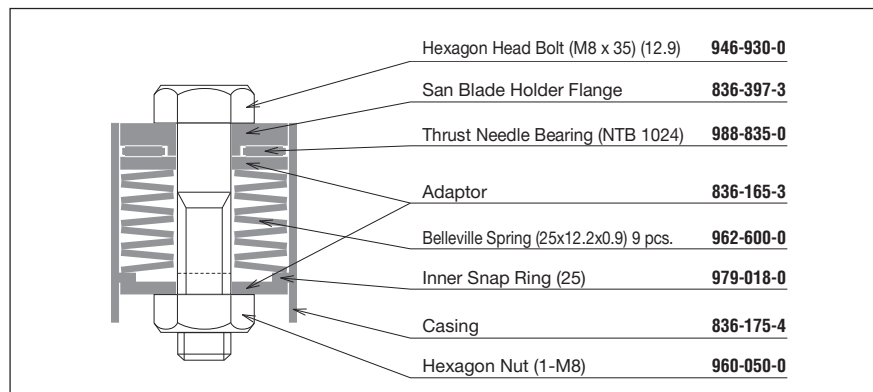

### Usage of Testing Attachment

#### Soft Joint

Typically 3 turns to full torque after the bolt head or nut seats on the surface.

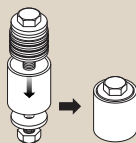

Apply Plate Springs, Testing Bolt (for soft-joint test) Spacer, Nut, and Casing. The Plate Springs are available in both weak and strong tensions.

#### Hard Joint

Typically 1/10 turn to full torque after the bolt head or nut seats on the surface



Apply Testing Bolt (for heard joint test) and Nut (without Casing, Spacer and Plate Spring).

# TESTERS

## UFT SERIES HYDRAULIC TESTER

Verify tool's performance with UFT prior to start of daily operation and you will find out less power on tools that can cause under torque troubles during the operation.



UFT-6



UFT-10



UFT-16



UFT-24

### FEATURES

- Hard and Soft joint can easily be changed.
- Equipped with digital display.
- Shift between Torque value and tension value can easily be changed.
- Decimal point can also be moved easily.
- Applicable for pulse tools, impact wrenches, angle nutrunner, and any other fastening tools.

### SPECIFICATIONS

Model	Bolt Size	Tension Range (kN)	Torque Range (Nm)	Weight (about)		Code	
				Kg	lb	120V	230V
UFT-6	M5	3.6-6.1	3.2-5.4	3.6	7.9	84022	84042
	M6	5.1-13.9	5.4-14.7				
UFT-10	M6	5.1-13.9	5.4-14.7	12.0	26.4	84032	84052
	M8	10.4-22.2	14.7-31.4				
	M10	17.8-30.6	31.4-53.9				

Model	Bolt Size	Tension Range (kN)	Torque Range (Nm)	Weight (about)		Code	
				Kg	lb	120V	230V
UFT-16	M12	25.5-41.7	53.9-88.2	22.0	48.4	84092	84062
	M14	35.7-60.3	88.2-149				
	M16	52.8-67.4	149-190				
UFT-24	M18	59.9-92.6	190-294	50.0	110.0	84082	84072
	M20	83.3-125	294-441				
	M24	104-162	441-686				

\*Never provide UFT with torque greater than maximum torque or tension of each bolt size.

## UHT SERIES HYDRAULIC TORQUE TESTER

The UHT-series simply designed hydraulic torque testers are suitable to be applied to Screwdrivers (Cushion, Positive, Impact Clutch types), Impact Wrenches and similar Impact action fastening tools in monitoring torque output of new and repaired tools in comparison with their master tools. The readout in the dial indicator does not show absolute torque value, but just comparative degree of power of the tool being tested.



UHT-35

UHT-25

UHT-12



UHT-50

### SPECIFICATIONS

Model	Applicable Tool Type or Square Drive Size	Applicable Torque Range		Weight (about)		Code
		Nm	ft-lbs	Kg	lb	
UHT-12	Cushion/Positive Clutch	1-8	0.7-5.9	2.5	5.5	83912
UHT-16	Impact Clutch	3-20	2.2-14.8	7.5	16.5	83812
UHT-25	3/8"(9.5mm)	20-50	14-36	13.0	28.6	84012
UHT-35	1/2"(12.7mm)	50-300	36-215	19.0	41.8	84112
UHT-50	3/4"-1"(19.0-25.4mm)	300-2000	215-1450	150.0	330.0	84212