



Bucket Lid with Agitator Pressure Tank



Stainless steel bucket lid with agitator

Fluid outlet
(Ø35mm)
(1.37in)

Fluid inlet
(Ø15mm)
(0.59in)

RB-TP



Air Motor	M10	M30
Motor power	1/16HP	1/4HP
Capacity	20(L)	
Blade size	Ø95mm (3.74 in)	
Axes size	Ø12x335mm (0.47x13.12 in)	
Dimension	380x350x225mm (14.96x13.78x8.86 in)	
Weight	5.1kg (11.24 lbs)	
Material	Stainless steel	

Size diagram

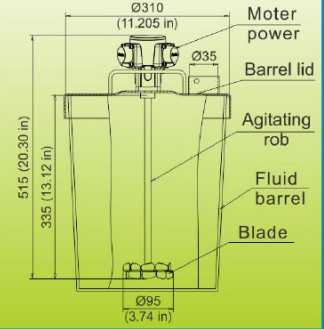

Small Pressure Tank



RC-2E



RT-2E



RT-5M



RT-5A



RT-5E



RT-5AS



RT-5ES

Pressure Tank



RT-10M



RT-10A



RT-10E



RT-10AS



RT-20M



RT-20E



RT-20AIS



RT-20AS



RT-40M



RT-40A



RT-40E



RT-40AIS



RT-40MIS



RT-40ASFG



RT-40MS



RT-60M



RT-60A



RT-60E



Functional specification of automotive pressure tank

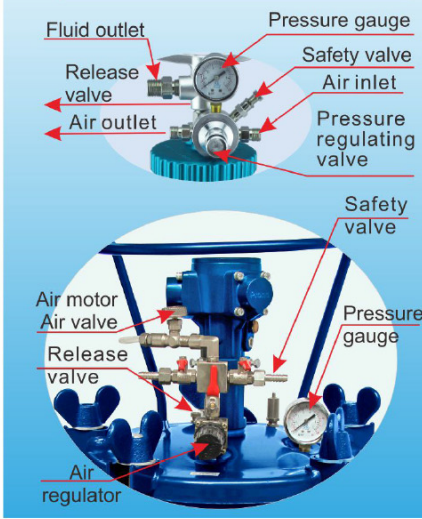

Functions and Characteristics (Small Amount Spray)

- ◆ The fluid liner bucket of RT-5E is made of SUS stainless steel.
- ◆ RC-2E and RT-2E are integrated molding of aluminum-alloy with anodize process on the surface, provide high safety performance.
- ◆ It is light weight and portable.
- ◆ **Warning: No to operate the pressure tank exceed the maximum pressure (0.3 Mpa). Prona Tools Inc will not hold any responsibility in case of accidents occur due to improper use of product.**
- ◆ **Do not use aluminum-corrosion material.**

Functions and Characteristics (Mass Amount Spray)

- ◆ Pressure tank is manufactured by integrated molding of pressure resistant steel plate. Its surface received special antirust treatment, provide high safety. Fluid feed can be siphoned from the top - suitable for normal fluid or drand at the bottom of the tank - suitable for high viscosity fluid. (subject to the size of the tank).
- ◆ The pressure tank can be classified into three types: with agitator, with manual agitator and pressure pot only.
- ◆ The pressure tank also equipped with an fluid liner bucket, which is made by SUS304 stainless steel (subject to the size of the tank).
- ◆ **Warning: Do not operate the pressure tank exceed the maximum pressure. Prona Tools Inc will not hold any responsibility in case of accidents occur due to improper use of product.**

Paint pressurized tank

Application NO: 2018 2 0637833. 2

Use	Operation	Model	Capacity	Pressure	Fluid outlet	Fluid liner bucket size	Net weight	
			L	Mpa(kgf/cm ²)		Ømmxmmm	kg	
Small Amount Spray	Economy	RT-2E	2	0.3(3)	1/4x1	129.5x199	1.52(3.35)	
		RC-2E	2		3/8x1		1.54(3.4)	
	Manual	RT-5M	5		1/4x1		9.6(21.16)	
		RT-5M	5				9.4(20.72)	
	Automatic	RT-5A	5				10.7(23.57)	
RT-5AS		5	10(22.05)					
Economy	RT-5E	5	8.6(18.96)					
Mass Amount Spray	Manual	RT-10M	10	0.3(3)	1/4x1	248x185(9.76x7.28)	16.8(37.04)	
		RT-20M	20				26.4(58.2)	
		RT-40M	40				0.19(1.9)	31.4(69.23)
		RT-60M	60					34.1(75.18)
	Manual (Stainless)	RT-10MS	10	0.3(3)	1/4x1	248x185(9.76x7.28)	16.7(36.82)	
		RT-20MS	20				27.9(61.5)	
		RT-40MS	40				0.19(1.9)	34.2(75.4)
		RT-60MS	60					35.9(79.15)
	Manual (Stainless bucket lid)	RT-20MIS	20	0.3(3)	1/4x2	292x365(11.5x14.37)	27(59.52)	
		RT-40MIS	40				0.19(1.9)	33.3(73.41)
		RT-60MIS	60					35(77.16)
		Mass Amount Spray	Automatic				RT-10A	10
RT-20A	20			28(61.73)				
RT-40A	40			0.19(1.9)	32.8(72.31)			
RT-60A	60				35.9(79.15)			
Automatic (Stainless)	RT-10AS		10	0.3(3)	1/4x1	248x185(9.76x7.28)	18.8(41.45)	
	RT-20AS		20				29.5(65.04)	
	RT-40AS		40				0.19(1.9)	35.6(78.48)
	RT-60AS		60					38.7(85.32)
Automatic (Stainless bucket lid)	RT-20AIS		20	0.3(3)	1/4x2	292x365(11.5x14.37)	28.4(62.61)	
	RT-40AIS		40				0.19(1.9)	34.7(76.5)
	RT-60AIS		60					37.8(83.33)
	Mass Amount Spray		Economy				RT-10E	10
RT-20E		20		25.2(55.56)				
RT-40E		40		0.19(1.9)	29.6(65.27)			
RT-60E		60			32.2(70.99)			
Economy (Stainless)		RT-10ES	10	0.3(3)	1/4x1	248x185(9.76x7.28)	15.4(33.95)	
		RT-20ES	20				26.7(58.68)	
		RT-40ES	40				0.19(1.9)	31.1(68.56)
		RT-60ES	60					35(79.37)
Mass Amount Spray	Manual (Lower)	RT-10MFG	10	0.3(3)	3/4x1	248x185(9.76x7.28)	17.3(38.14)	
		RT-20MFG	20				26.9(59.3)	
		RT-40MFG	40				0.19(1.9)	31.9(70.33)
		RT-60MFG	60					34.8(36.72)
	Manual (Lower) (Stainless)	RT-10MSFG	10	0.3(3)	3/4x1	248x185(9.76x7.28)	17.3(38.14)	
		RT-20MSFG	20				28.4(62.61)	
		RT-40MSFG	40				0.19(1.9)	34.7(76.5)
		RT-60MSFG	60					36.6(80.69)
	Manual (Lower) (Stainless bucket lid)	RT-20MISFG	20	0.19(1.9)	3/4x1	292x365(11.5x14.37)	27.5(60.68)	
		RT-40MISFG	40				0.19(1.9)	33.8(74.52)
		RT-60MISFG	60					35.7(78.71)
		Mass Amount Spray	Automatic (Lower)				RT-10AFG	10
RT-20AFG	20			26.9(59.3)				
RT-40AFG	40			0.19(1.9)	31.9(70.33)			
RT-60AFG	60				34.8(76.72)			
Automatic (Lower) (Stainless)	RT-10ASFG		10	0.3(3)	3/4x1	248x185(9.76x7.28)	17.2(37.92)	
	RT-20ASFG		20				28.4(62.61)	
	RT-40ASFG		40				0.19(1.9)	34.7(76.15)
	RT-60ASFG		60					36.6(80.69)
Automatic (Lower) (Stainless bucket lid)	RT-20AISFG		20	0.3(3)	3/4x1	292x365(11.5x14.37)	27.5(60.62)	
	RT-40AISFG		40				0.19(1.9)	33.8(74.52)
	RT-60AISFG		60					35.7(78.70)
	Mass Amount Spray		Economy (Lower)				RT-10EFG	10
RT-20EFG		20		28.5(62.83)				
RT-40EFG		40		0.19(1.9)	33.3(72.75)			
RT-60EFG		60			36.4(80.25)			
Economy (Lower) (Stainless)		RT-10ESFG	10	0.3(3)	3/4x1	248x185(9.76x7.28)	19.3(42.55)	
		RT-20ESFG	20				30(66.14)	
		RT-40ESFG	40				0.19(1.9)	36.1(79.59)
		RT-60ESFG	60					39.2(86.42)