



"Digital direct reading system" for hole pitch through easy operation

Direct reading system
Digital

For center distance measurement "between holes"

E-RX30B

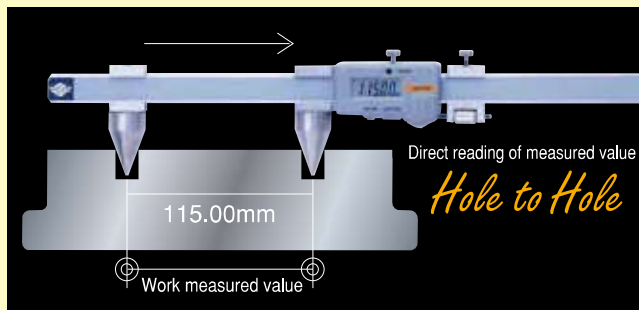
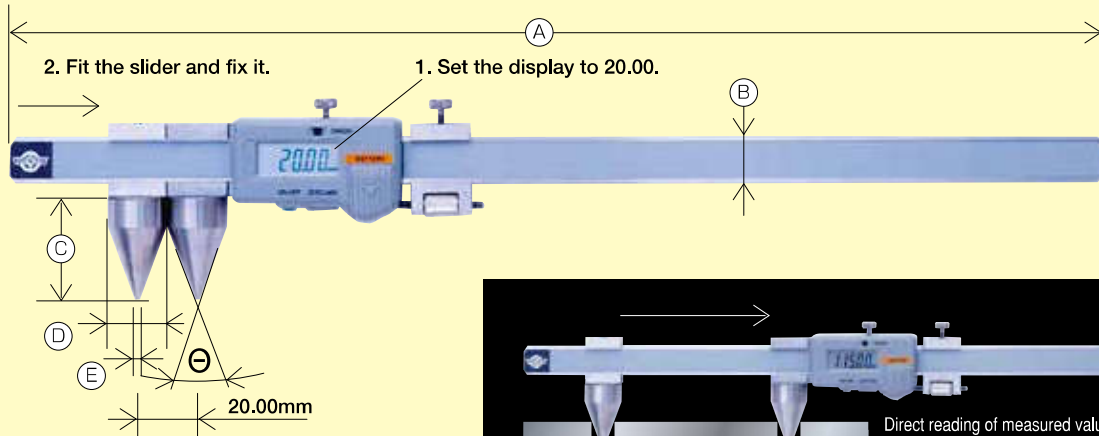

- The center distance of holes can be measured through direct reading. Holes with a diameter of 19 mm at the maximum can be measured.
- The printer output function is provided.

E-RX : Specifications

(Unit : mm)

Model	Measuring length	Resolution	Instrumental error	Minimum hole diameter	Maximum hole diameter	Power supply	Weight	A	B	C	D	E	Θ
E-RX20B	20~200	0.01	±0.03	φ3	φ19	SR44 1 piece	360g	370	16	35	φ20	φ2	40°
E-RX30B	20~300												

For measurement of distance "between edge face and hole"

E-RZ30B

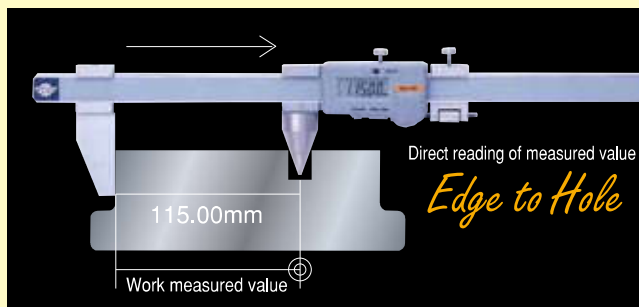
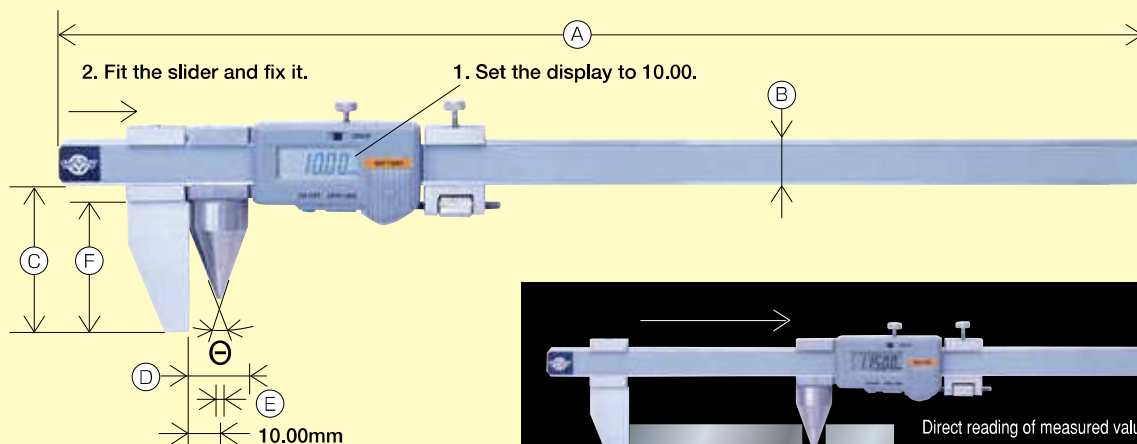

- The distance between edge face and hole can be measured through direct reading. Holes with a diameter of 19 mm at the maximum can be measured.
- The printer output function is provided.

E-RZ : Specifications

(Unit : mm)

Model	Measuring length	Resolution	Instrumental error	Minimum hole diameter	Maximum hole diameter	Power supply	Weight	A	B	C	D	E	F	Θ
E-RZ20B	10~200	0.01	±0.03	φ3	φ19	SR44 1 piece	340g	370	16	50	φ20	φ2	45	40°
E-RZ30B	10~300													

E-RM-J

Centerline caliper for distance between center to center of holes with equal diameter



Adequate for center to center distance measurement!

Direct reading system
Digital

One unit for
two functions

E-RM15J



Measurement of distance between center to center of holes

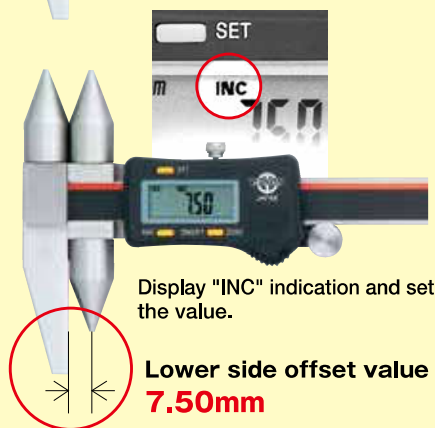
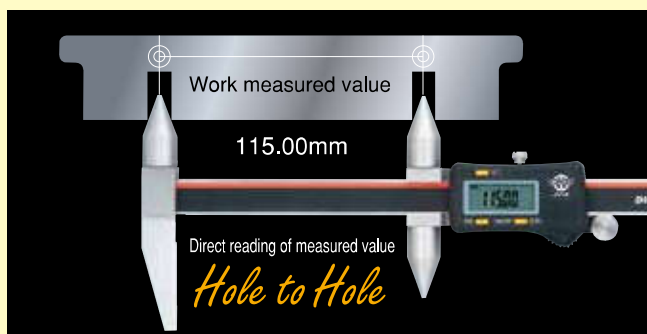
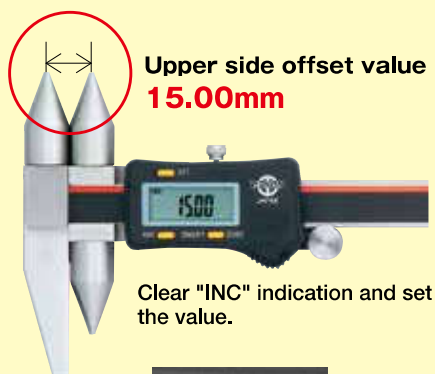

Measurement of distance between edge face and hole



- By setting the upper side offset value (15.00 mm) and the lower offset value (7.50 mm), this instrument allows the measured center distance to be indicated as actual size. This saves time for addition or subtraction of indicated value that is required by former instruments, resulting easier use.

- Since one unit of this caliper allows measurement of center distance of holes and distance between edge face and hole through direct reading, the product eliminates the need for preparing two units for two types of measurement, resulting in convenient use.
- Offset value setting in the upper side and the lower side can be easily conducted by pressing the "SET" button.

■ E-RM-J : Specifications

(Unit : mm)

Model	Measuring range		Resolution	Instrumental error	Minimum hole diameter	Maximum hole diameter	Power supply	Weight	A	B	C	D	E	F	G	H	θ
	Pitch for upper side	Pitch for lower side															
E-RM15J	15~150	7.5~150	0.01	±0.05	φ 3	φ 14	SR44 1 piece	300g	260	50	16	φ15	φ1.9	38	32	71	40°
E-RM20J	15~200	7.5~200						340g	310								
E-RM30J	15~300	7.5~300						380g	405								

E-RX-J

Adequate for center distance measurement for holes at different levels



Digital direct reading of center distance measurement "between holes with equal diameter at different levels"

Direct reading system
Digital

E-RX30J

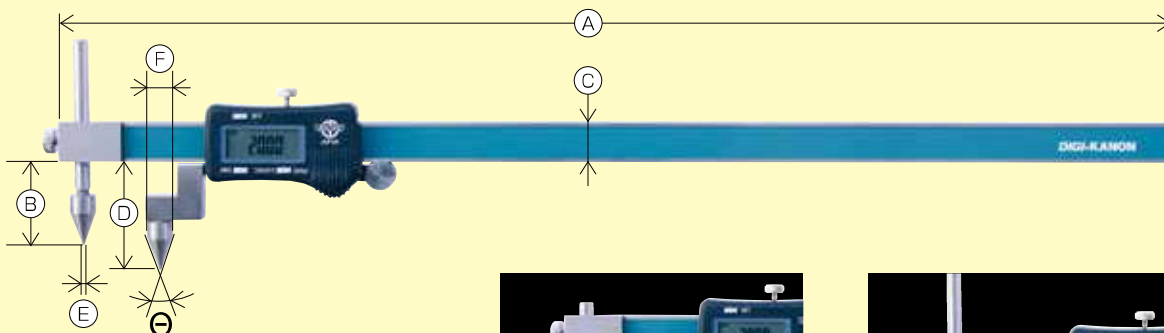

- Since the probe of main scale moves vertically, center distance measurement between holes at different levels is available.



E-RX-J : Specifications

(Unit : mm)

Model	Measuring range	Resolution	Instrumental error	Minimum hole diameter	Maximum hole diameter	Power supply	Weight	A	B	C	D	E	F	Θ
E-RX30J	10~300	0.01	±0.05	φ 2	φ 9	SR44 1 piece	300g	435	18~52	16	42	φ 1	φ 10	40°

RM-DX

Centerline caliper for distance between center to center distance of holes with equal diameter



Adequate for center to center distance measurement!

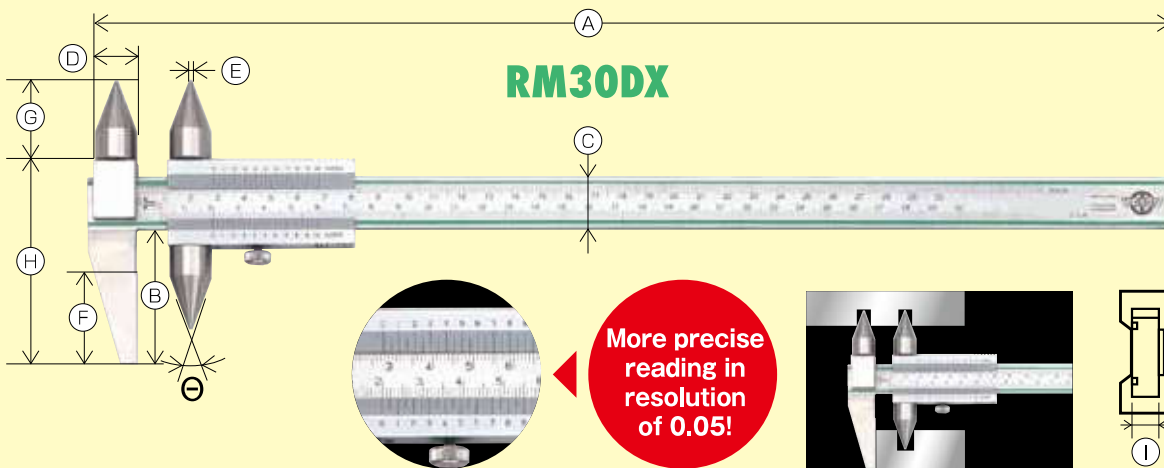

RM-DX : Specifications

(Unit : mm)

Model	Measuring range		Minimum reading	Instrumental error	Minimum hole diameter	Maximum hole diameter	Weight	A	B	C	D	E	F	G	H	I	Θ					
	Pitch for upper side	Pitch for lower side																				
RM15DX	17~150	9~150	0.05 (Division of 39 mm into 20 equal parts)	±0.07	φ 3	φ 15	400g	280	50	20	φ16	φ1.9	34	31	76	4	40°					
RM20DX	17~200	9~200					430g	330														
RM30DX	17~300	9~300					500g	410														
RM60DX	17~600	9~600					1.16kg	780										85	25	69	116	6
RM100DX	21~1000	11~1000					3.15kg	1200										90	32	φ20	φ4	67

RM(II)

Offset centerline caliper



For center to center distance with different diameters!

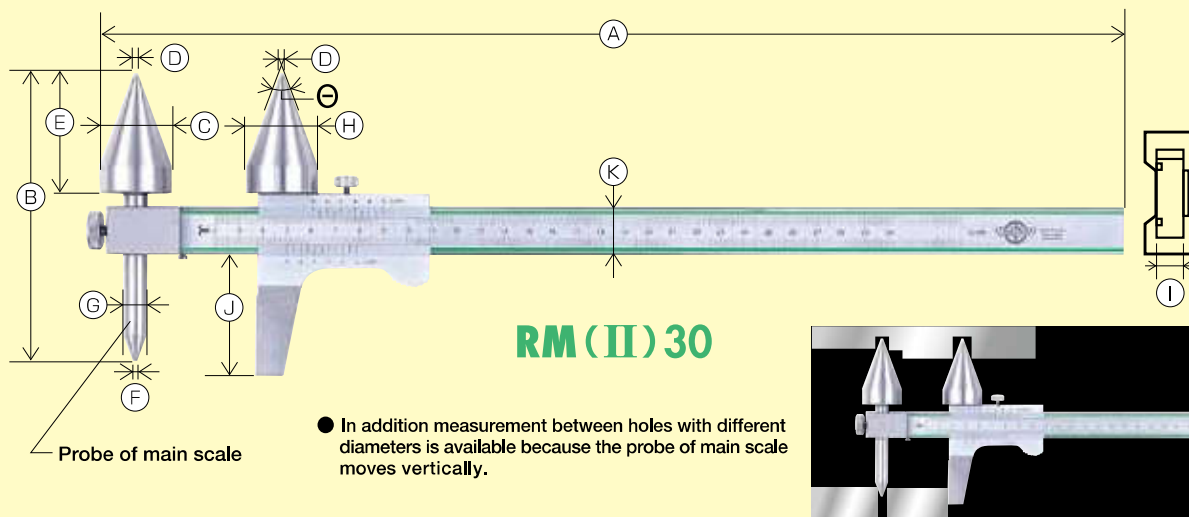

RM(II) 30

● In addition measurement between holes with different diameters is available because the probe of main scale moves vertically.

■ RM(II) : Specifications

(Unit : mm)

Model	Measuring range		Minimum reading	Instrumental error	Minimum hole diameter	Maximum hole diameter	Weight	A	B	C	D	E	F	G	H	I	J	K	θ
	Pitch for upper side	Pitch for lower side																	
RM(II)15	25~150	20~150	0.1 (Division of 29 mm into 10 equal parts)	±0.07	φ 1	φ 5	180g	261	70	φ 6	φ 0.2	—	φ 0.2	φ 6	φ 6	3	40	16	53°
RM(II)30	35~300	25~300		±0.08	φ 3	φ 29	550g	422	120	φ 30	φ 2	50	φ 2	φ 10	φ 30	4	50	20	40°
RM(II)60	35~600	25~600		±0.11			1.3kg	781											
RM(II)100	50~1000	40~1000		±0.15	φ 5	3.5kg	1233	124	φ 4	42	φ 4	φ 12	8	80	32				

Probe of main scale

RM-S

Adequate for center distance measurement for small diameter holes



Vernier caliper for measuring circular hole center distance adequate for "small diameter hole".

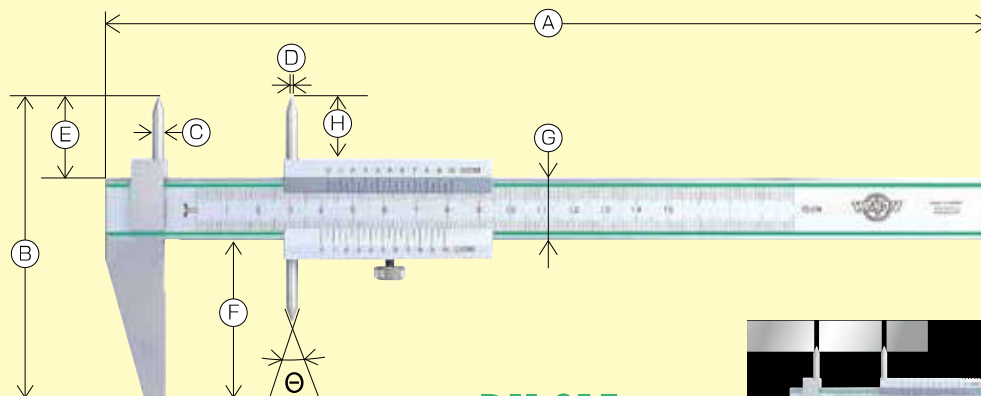

RM-S15

■ RM-S : Specifications

(Unit : mm)

Model	Measuring range		Minimum reading	Instrumental error	Minimum hole diameter	Maximum hole diameter	Weight	A	B	C	D	E	F	G	H	θ
	Pitch for upper side	Pitch for lower side														
RM-S15	5~150	3~150	0.05 (Division of 39 mm into 20 equal parts)	±0.07	φ 1	φ 3.5	180g	280	96	φ 4	φ 0.8	26	50	20	20	40°

E-RM60B

Adequate for center distance measurement for holes with equal diameter on long work



With "measuring length of 600 mm", this large digital caliper is adequate for measuring holes with equal diameter on long work.

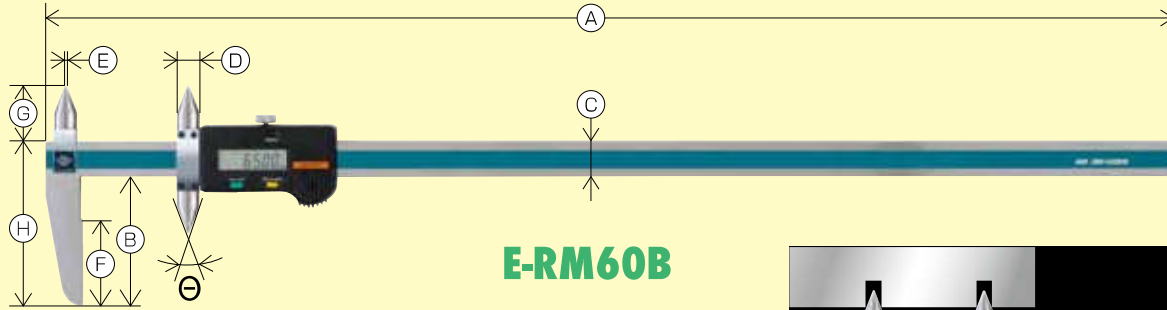

E-RM60B

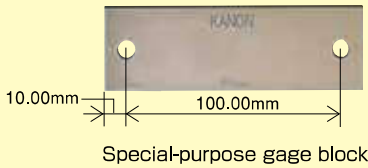

- Long vernier caliper that allows measurement of center distance of two holes with an equal diameter and measurement of distance between edge face and hole center.
- A special-purpose gage block is provided.
- The printer output function is provided.

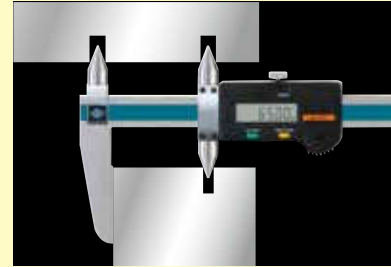

E-RM60B : Specifications

(Unit : mm)

Model	Measuring range		Resolution	Instrumental error	Minimum hole diameter	Maximum hole diameter	Power supply	Weight	A	B	C	D	E	F	G	H	θ
	Pitch for upper side	Pitch for lower side															
E-RM60B	17~600	9~600	0.01	±0.05	φ 3	φ 15	SR44 1 piece	2.4kg	780	85	25	φ16	φ1.9	69	31	110	40°

E-RM30DX

Adequate for distance measurement between wall surface and hole



Direct reading type multi-functional digital scale for measuring circular hole center distance that allows "three types of measurement" by replacing the probe

Direct reading system Digital

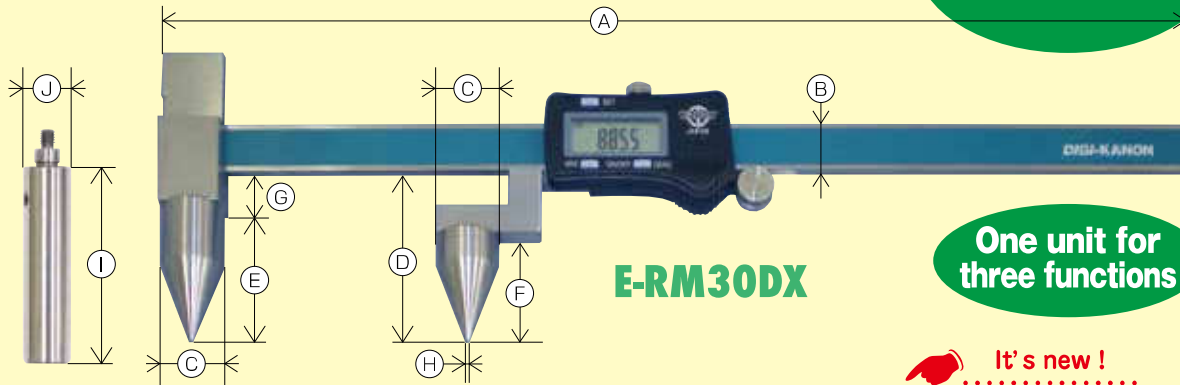

E-RM30DX

One unit for three functions

It's new!

Pitch measurement between holes

Distance measurement between edge face and hole

Distance measurement between wall surface and hole

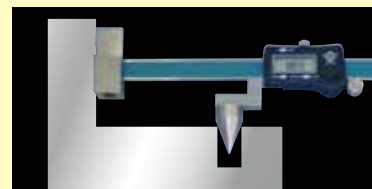
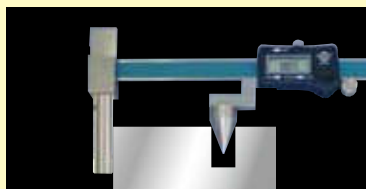
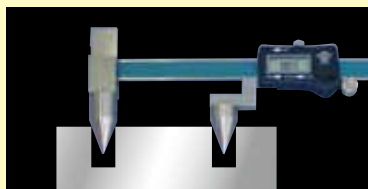

E-RM30DX : Specifications

(Unit : mm)

Model	Measuring range		Resolution	Instrumental error	Minimum hole diameter	Maximum hole diameter	Power supply	Weight	A	B	C	D	E	F	G	H	I	J
	Edge/wall to hole	Hole to hole																
E-RM30DX	10~300	20~300	0.01	±0.05	φ 3	φ 19	SR44 1 piece	550g	430	16	φ20	57	45	35	12	φ2	60	φ15

E-RM(II) / E-RM-S

Adequate for center distance measurement for holes



Caliper for measuring circular hole center distance adequate for "offset system" with vertical movement of probe and measurement of "small diameter hole and small surface"

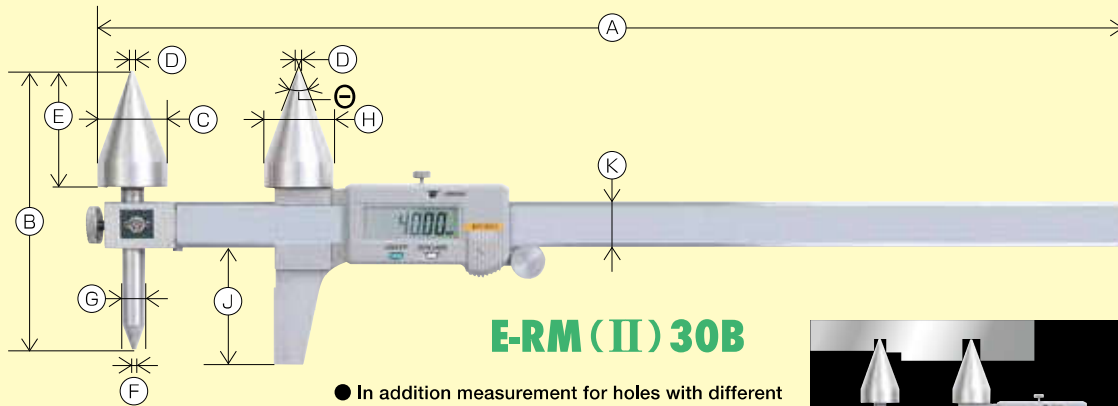

E-RM(II) 30B

- In addition measurement for holes with different diameters is available because the probe of main scale moves vertically.
- A special-purpose gage block is provided.
- The printer output function is provided.

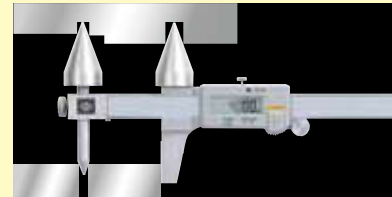

E-RM(II) : Specifications

(Unit : mm)

Model	Measuring range		Resolution	Instrumental error	Minimum hole diameter	Maximum hole diameter	Power supply	Weight	A	B	C	D	E	F	G	H	J	K	Θ												
	Pitch for upper side	Pitch for lower side																													
E-RM(II)15B	25~150	20~150	0.01	±0.05	φ1	φ5	SR44 1 piece	160g	254	70	φ6	φ0.2	—	φ0.2	φ6	φ6	40	16	53°												
E-RM(II)30B	35~300	25~300			φ3	φ29														530g	438	120	φ30	φ2	50	φ2	φ10	φ30	50	20	40°
E-RM(II)60B	35~600	25~600			φ3	φ29														1.7kg	799	70	φ30	φ2	70	φ2	φ10	φ30	70	25	

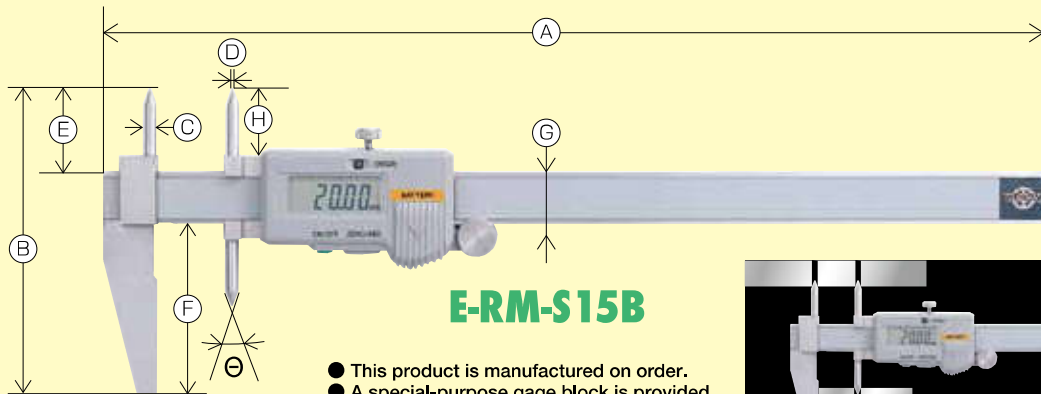

E-RM-S15B

- This product is manufactured on order.
- A special-purpose gage block is provided.
- The printer output function is provided.



E-RM-S : Specifications

(Unit : mm)

Model	Measuring range		Resolution	Instrumental error	Minimum hole diameter	Maximum hole diameter	Power supply	Weight	A	B	C	D	E	F	G	H	Θ
	Pitch for upper side	Pitch for lower side															
E-RM-S15B	5~150	3~150	0.01	±0.05	φ1	φ3.5	SR44 1piece	160g	280	90.7	φ4	φ0.8	24.7	50	16	20	40°

Method of setting with special-purpose gage block

Method of measurement on upper and lower sides with E-RM-B series (E-RM60B/E-RM(II)-B/E-RM-S-B) special-purpose gage block

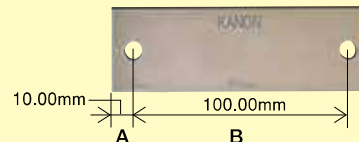

Special-purpose gage block

[In case of E-RM60B]

Measurement on lower side

Position the lower measurement section to the dimension A side of the gage block.
At this time, ensure that no clearance of measuring surface is present in the edge face side.
Press the ON/OFF switch and then press the ZERO/ABS switch.
At this time, dimension A of 10 mm becomes the zero point.

* When the measured value is indicated, add or subtract it to or from dimension A of 10 mm.

- (Example 1) If "8.00" is indicated:
8.00 + 10 mm (dimension A) = 18.00 mm (actual size)
(Example 2) If "-0.05" is indicated:
-0.05 + 10 mm (dimension A) = 9.95 mm (actual size)

Measurement on upper side

Position the upper measurement section to the dimension B side of the gage block.
At this time, ensure that the probe is securely inserted into the hole.
Press the ON/OFF switch and then press the ZERO/ABS switch.
At this time, dimension B of 100 mm becomes the zero point.

* When the measured value is indicated, add or subtract it to or from dimension B of 100 mm.

- (Example 3) If "25.00" is indicated:
25.00 + 100 mm (dimension B) = 125.00 mm (actual size)
(Example 4) If "-25.00" is indicated:
-25.00 + 100 mm (dimension B) = 75.00 mm (actual size)