

UEC SERIES (Single Spindle Connection)

UEC-4800TP (SD) / UEC-4800TP (SD-ANGLE)

The Touch Panel type visualizes all fastening results.

BOLT & NUT SETTERS



FEATURES

- Ethernet(TCP/IP) capable.
- You can see Torque Wave data on both front touch panel and PC.

[Top Screen]



[Wave form Screen]



- You can detect various fastening errors and control the job with fastening counter.
- UEC-4800TPA/E(SD) Series can be used for 16 different fastening applications.
- Front panel, PC display or buzzer will tell you Input/Output (terminal blocks & tool wiring) checks and errors.
- UEC-4800TPA/E(SD) Series memorizes max. 4,550 fastening data (max. 1,900 fastening data when ID data is included). Standard deviations, Cp value, Cpk value can be analyzed instantly from the stored data within the controller. When you connect UEC-4800TPA/E(SD) Series to PC, you can graph the statistical data.
- By using Input/Output terminals UEC-4800TPA/E(SD) Series can be interlocked with the production line.

UEC-4801 / UEC-4801 (ANGLE)

Cost-Effective LCD-Panel Available

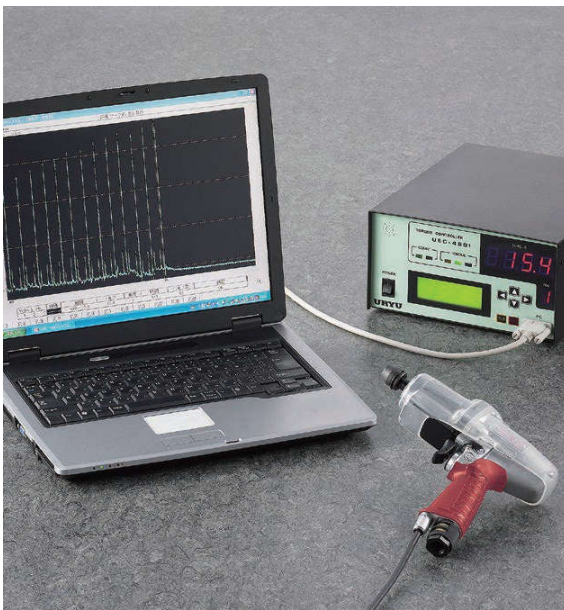

FEATURES

- LCD-Panel type is available for more cost effective.
- Setting parameters can be put into the controller on the front panel as well as PC.

[FUNCTIONS]

- You can see Torque Wave data on PC connected to LCD-Panel type.

*The other features and functions are the same from UEC-4800TPA/E(SD) and UEC-4800TPA/E(SD-ANGLE).

SPECIFICATIONS

Models	UEC-4800TPA/E (SD)	UEC-4800TPA/E (SD-ANGLE)	UEC-4801A/E	UEC-4801A/E (ANGLE)
POWER SUPPLY	AC100 ~ 240V ±10%		AC100 ~ 240V ±10%	
POWER FREQUENCY	50/60 Hz		50/60 Hz	
NOISE PROTECTION	1000V 1μS (according to noise simulator)		1000V 1μS (according to noise simulator)	
INSULATION PROTECTION	DC500V over 10MΩ		DC500V over 10MΩ	
AMBIENT TEMPERATURE	0 ~ 50°C (non-freezing)		0 ~ 50°C (non-freezing)	
AMBIENT HUMIDITY	Under 90%RH (no dew)		Under 90%RH (no dew)	
POWER CONSUMPTION	Approx. 30VA		Approx. 30VA	
WEIGHT	Approx. 3.6 kg		Approx. 3.6 kg	
DIMENSIONS	265(D) x 222(W) x 120(H)		265(D) x 222(W) x 120(H)	
MAIN FUNCTIONS	Torque Control + Fastening Counter		Torque Control + Fastening Counter	
ANGLE MONITORING	—		—	
PARAMETER SETUP	Manual Input on Front Touch Panel Personal Computer (with setup software)		Manual Input on Front LCD Panel Personal Computer (with setup software)	
DISPLAY	Torque Resolution ±2048 (12Bit A/D) 320 x 240 dot 25 characters x 15 lines		Torque Resolution ±2048 (12Bit A/D) LCD : 20 characters x 4 lines Contents : WORK NO. / FASTENING COUNT DOWN NO. / FASTENING TIME / PULSE NO. 1-digit digital display (DPM) : WORK NO. 4-digit digital display (DPM) : TORQUE	
LED	COUNT Lamp : OK (Green) / NOK (Red) TORQUE Lamp : LOW (Yellow) / OK (Green) /HIGH (RED)		COUNT Lamp : OK (Green) / NOK (Red) TORQUE Lamp : LOW (Yellow) / OK (Green) / HIGH (RED)	
INPUT TERMINAL SIGNAL	Operation Voltage/Current : DC24V/aprox. 10mA 6 terminals (free format), VALVE		Operation Voltage/Current : DC24V/aprox. 10mA 6 terminals (free format), VALVE	
OUTPUT TERMINAL SIGNAL	Contact Capacity : AC:125V, 0.3A, DC:30V, 1A 6 terminals (free format), VALVE		Contact Capacity : AC:125V, 0.3A, DC:30V, 1A 6 terminals (free format), VALVE	
OPTION	Setting PC Cable (Straight) Part Number : 910-219-0			
CODE (A/E)	81662/81672	81832/81842	81B42/81B52	81C42/81C52

Used with

Magnetostrictive Sensor Pulse Wrench	UAAMC Series / UAMC Series / UXR-MC Series
Strain-Gauge Sensor Pneumatic Nutrunner	UAN-RM Series

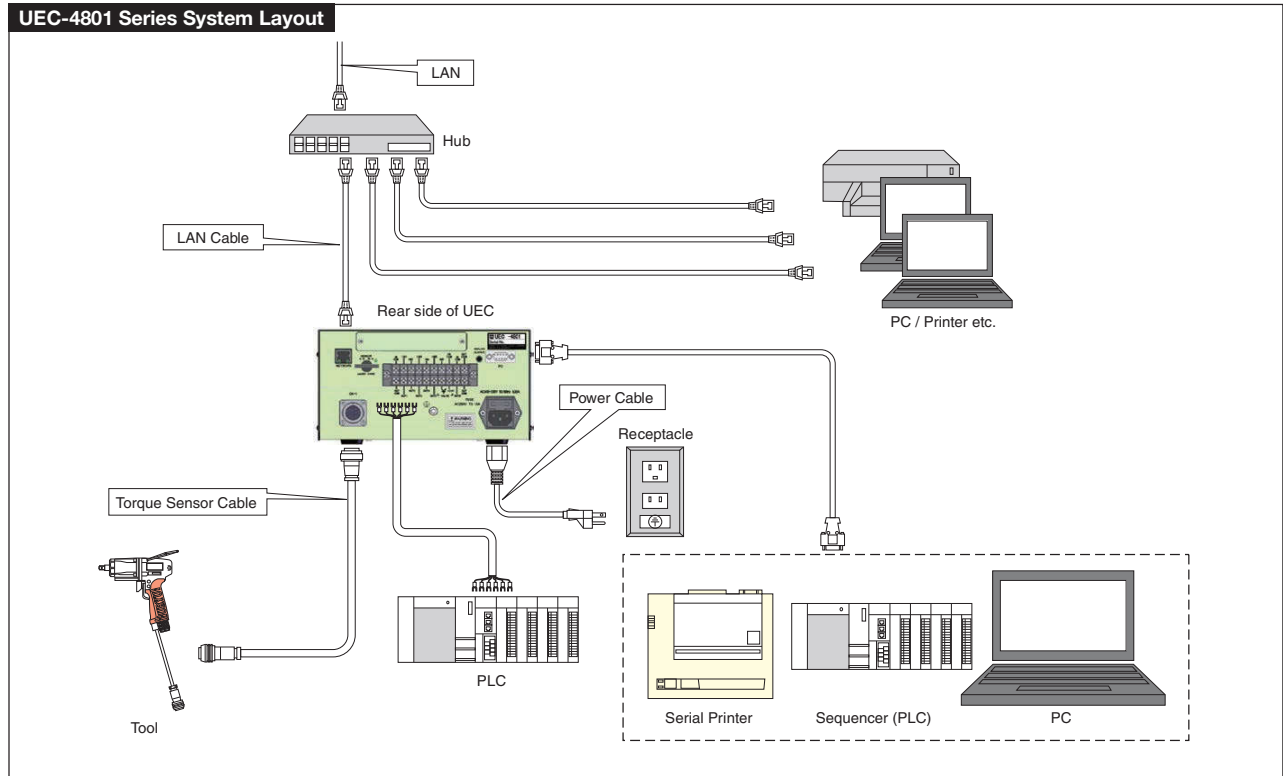

UEC SERIES (Multi Spindle Connection)

UEC-5500

Multi-function controller which can control 4-spindles simultaneously. UEC-5500 controls various error detections, the number of fasteners and pulse numbers for 4 different tools in one controller.

BOLT & NUT SETTERS



Used with

Magnetostrictive Sensor Pulse Wrench	UAMC Series / UXR-MC Series
Strain-Gauge Sensor Pneumatic Nutrunner	UAN-RM Series

*Key Pad (910-208-0) and Key Pad Cable (910-206-0) are optional items, so please purchase them separately.

FEATURES

- UEC-5500 can control max. 4 different transducerized tools simultaneously.
- UEC-5500 can be used with various type of transducerized tools.
 - Oil-Pulse Tools fitted with a brushless type Magnetostrictive Transducer.
 - UAMC Series, UXR-MC Series
 - Pneumatic Nutrunners fitted with a Strain-Gauged Transducer.
 - UAN-RM Series
- High Reliable Torque Control & Monitor.
- Easy Programming with a Removable Key Pad. You can also upload the fastening programmes from PC.
- Ethernet(TCP/IP) capable.

[FUNCTIONS]

- You can choose between Torque Control and Monitor. You can detect various errors and control the job with fastening counter.
- You can see 'Torque wave Data' on PC.
- Makes setup or changeover of fastening torque and fastening number count for 8 different fastening applications.
- Input/Output check and error messages can be checked from your PC screen or the front panel of UEC-5500 with buzzer sounding.
- For Oil-Pulse Tools, tool maintenance can be determined by the total numbers of fasteners as well as total pulse numbers.
- UEC-5500 memorizes max. 20,000 fastening data per spindle. By connecting to PC, you can download the stored data to your PC for statistical analysis of mean, σ , 3σ / mean, CP, and CPK. You can also graph the statistical data.
- By using Input / Output terminals UEC-5500 can be interlocked with the production line.

UEC-5500A/E SPECIFICATIONS

POWER SUPPLY	AC100~240V ±10%
POWER FREQUENCY	50 / 60 Hz
NOISE PROTECTION	1000V 1μS (according to noise simulator)
INSULATION PROTECTION	DC500V over 10MΩ
AMBIENT TEMPERATURE	0~50°C (non-freezing)
AMBIENT HUMIDITY	Under 90%RH (no dew)
POWER CONSUMPTION	Approx. 50VA
WEIGHT	Approx. 3.6 kg
DIMENSIONS	240(D) × 270(W) × 115(H)
MAIN FUNCTIONS	Torque Monitoring / Control + Fastening Counter
PARAMETER SETUP	Removable Key Pad Personal Computer (with setup software)
DISPLAY	Torque Resolution ±2048 (12Bit A/D)
	4-digit digital display : TORQUE
	2-digit digital display : FASTENING COUNT DOWN NO.
	1-digit digital display (small) × 4 : WORK NO. 1-digit digital display (large) × 4 : SPINDLE NO.
LED	Each Spindle's COUNT Lamp : OK (Green) / NOK (Red)
	TORQUE Lamp : LOW (Yellow) / OK (Green) / HIGH (RED)
INPUT TERMINAL SIGNAL	Drive by Electric Current Input (Photo Coupler Insulation)
	Voltage : DC24V Insulation Resistance : 4.7KΩ 12 terminals (free format)
OUTPUT TERMINAL SIGNAL	Contact Capacity : AC:125V, 0.3A, DC:30V, 1A
	8 terminals (free format), VALVE, +24V
OPTION	Setting PC Cable(Straight) Part Number : 910-219-0
CODE (A/E)	83272/83292

